

## HOW TO ORDER

KCF	25	B	J	2	100	
Product Code	RATED POWER		PACKING	Toleranc	No. of Total Character	Resistance Value
<b>KCF</b> : CARBON FILM RESISTOR <b>KMF</b> : METAL FILM RESISTOR <b>KRSF</b> : METAL OXIDE FILM RESISTOR <b>FKNP</b> : KNP WIRE WOUND FUSIBLE RESISTOR <b>NKNP</b> : WIRE WOUND RESISTORS (Non-Inductive) <b>KFR</b> : FUSIBLE RESISTOR <b>CR-M</b> : SQM CEMENT RESISTORS <b>CR-L</b> : SQP CEMENT RESISTORS	12	1/6W	T52 : TAPE/BOX T73: TAPE/BOX B: BULK R: TAPE REEL	F ±1% J ±5%	100=10R=2	100=10R
	25	1/4W			100R=101=3	100R=101
	50	1/2W			10K=1000=4	10K = 10,000
	12	1/6W				
	125	1/8W				
	100	1W				
	200	2W				
	1WS	1WS				
	2WS	2WS				
	500	5W				
700	7W					

## 1. GENERAL INSTRUCTION:

---

### 1-1. SCOPE

This specification applies to the Carbon Film Resistor Made By PROAN Electronics Co., Ltd

## 2. NOMINAL RESISTANCE:

The nominal resistance shall be the resistance marked on the resistor body and identified, as a rule, in units,  $\Omega$ ,  $K\Omega$ ,  $M\Omega$ .

## 3. NOMINAL RESISTANCE TOLERANCE.

The nominal resistance tolerance is represented in one capital letter selected from G( $\pm 2\%$ ), J( $\pm 5\%$ )

## 4. RATING:

### CF(CARBON FILM FIXED RESISTORS)

STYLE	MAX WORKING	MAX OVERLOAD	RESISTANCE VALUE RANGE
CF1/6W / CF1/8W	200V	400V	0.1 $\Omega$ ~ 22M $\Omega$
CF1/4W / CF1/4WS	250V	500V	0.1 $\Omega$ ~ 22M $\Omega$
CF1/2W / CF1/2WS	350V	700V	0.1 $\Omega$ ~ 22M $\Omega$
CF1W / CF1WS	500V	1000V	0.1 $\Omega$ ~ 22M $\Omega$
CF2W / CF2WS	500V	1000V	0.1 $\Omega$ ~ 22M $\Omega$
CF3W / CF3WS	500V	1000V	0.1 $\Omega$ ~ 22M $\Omega$
CF5W / CF5WS	500V	1000V	0.1 $\Omega$ ~ 22M $\Omega$

### 4-1. POWER RATING

power rating is defined as maximum power rating continuously applied under ambient temperature at 70°C. when the ambient temperature exceeds 70°C, use chart 1.

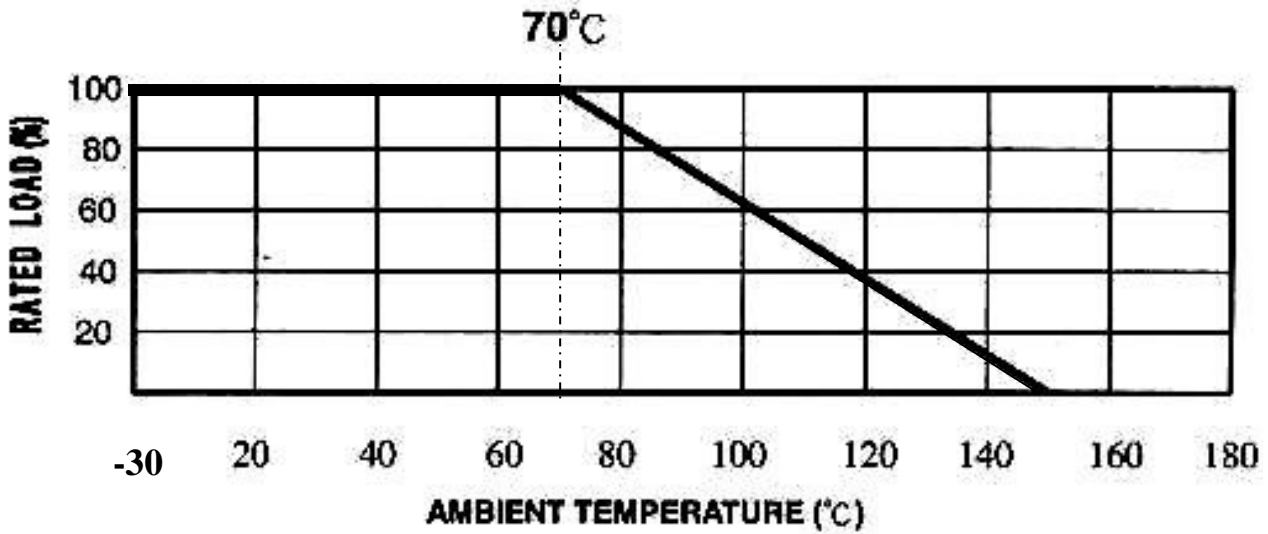

#### 4-2. RATED VOLTAGE

Rated voltage is defined as the DC or (AC effective Value at commercial frequency example 50 C/S, 60 C/S) Voltage when rated power is applied and can be calculated

By the following EQUATION  $E = \sqrt{P \cdot R}$

E=RATED VOLTAGE

P=RATED POWER (WATTS)

R=NOMINAL RESISTANCE VALUE (OHM)

When the calculated rated voltage exceeds the Maximum usable voltage flue shown in CHART 1, the Maximum usable voltage is defined as the voltage According to the power-decreasing curve shown in CHART1.

ITEM (STANDARD)	PERFORMANCE AND/OR QUALITY ACCEPTANCE	TEST METHOD
Resistance value Vs Temperature Characteristics	For $R_x < 100K\Omega$ +350 ~ -500PPM/°C $100K\Omega \leq R_x \leq 1M\Omega$ 0 ~ -700PPM/°C $1 M\Omega < R_x$ 0 ~ -1500PPM/°C	JIS-C-5202 5.2 Measure resistance ( $R_o$ ohm) at room Temperature( $T_o$ °C) Measure again the same at 100°C Higher than room temperature $PPM = \frac{R - R_o}{R_o} * \frac{10^6}{(T_o + 100) - T_o}$
Short time overload	The resistance variation shall be within $\pm(0.75\% + 0.05 \text{ ohm})$ and there shall be no mechanical breakage	JIS-C-5202 5.5 Apply DC voltage 2.5times the rated Voltage for 5 seconds The leave at room temperature for 30 Minutes then measure MAX overload Voltage 0.50W - 700V (DC)

ITEM (STANDARD)	PERFORMANCE AND/OR QUALITY ACCEPTANCE	TEST METHOD
Insulation resistance	1000M ohm or more	JIS-C-5202 5.6 In V-BLOCK Lay the resistor on 90° angle metal V Block apply 100VDC between resistor Lead and V block for one Minute And Measure
Voltage endurance	The resistance variation shall be within $\pm(2\% + 0.05\text{ohm})$ and there shall be no mechanical breakage	JIS-C-5202 5.7 Icy the resistor on the 90° angle metal V Block and apply reamed AC voltage for One Minute. Test voltage 0.25W – 500V (AC) 0.50W – 700V(AC)
Intermittent overload	Resistance variation shall be Within $\pm(2.00\% + 0.05\text{ohm})$	JIS-C-5202 5.8 Apply AC voltage 4 times the rated voltage for 1 second and rest for 25 seconds and Repeat this cycle for 10000 $\pm$ 200times leave resistor 30 minutes at room temperature after test and measure Maximum voltage for intermittent Overload.0.50W-700V(AC)
Terminal strength	Resistance variation shall be within $\pm(0.5\% + 0.05\text{ohm})$ also there Shall be on mechanical breakage	Pull test: apply 2.5kg force to the lead in the direction of lead axislor 30 $\pm$ 5 seconds.
Heat resistively Against soldering	Resistance variation shall be within $\pm(1.0\%+0.05\text{ohm})$ also there Shall be on mechanical breakage	JIS-C-5202 7.10 Dip the lead in to a solder bath having a Temperature of 350°C $\pm$ 10°C up to 4 $\pm$ 0.8mm from the body of the resistor at room temperature 3 hours after ,then Measure
Solder ability	More than 95% of the surface of the lead shall be covered by new solder after the leads are dipped in the Solder	JIS-C-5202 6.5 Dip the lead in to a solder bath having a Temperature of 260°C $\pm$ 5°C up to 4 $\pm$ 0.8mm from the body of the resistor and hold it for 5 $\pm$ 0.5seconds then inspect
Humidity load test	Resistance variation be Within $\pm(3.0\% + 0.05\text{ohm})$ Also there shall be mo mechanical breakage	JIS-C-5202 7.9 In temperature chamber having temperature 40°C $\pm$ 2°C,relative humidity 90 – 95%, Apply rated voltage 1.5hour and shut voltage 0.5 hour repeat this cycle for 1000 hours, leave in room temperature for lhour after test, then measure
Load life test	The variation of the resistance Shall be within $\pm(3\%+0.05\text{ohm})$ Also there shall be no mechanical Breakage	JIS-C-5202 7.10 In the constant temperature chamber having Temperature70°C $\pm$ 2°C,apply rated Dc voltage for 1.5hour and shut voltage for 0.5 hour and repeat thin cycle for 1000 hours, leave in room temperature lhour after test, then measure

### 5. Marking

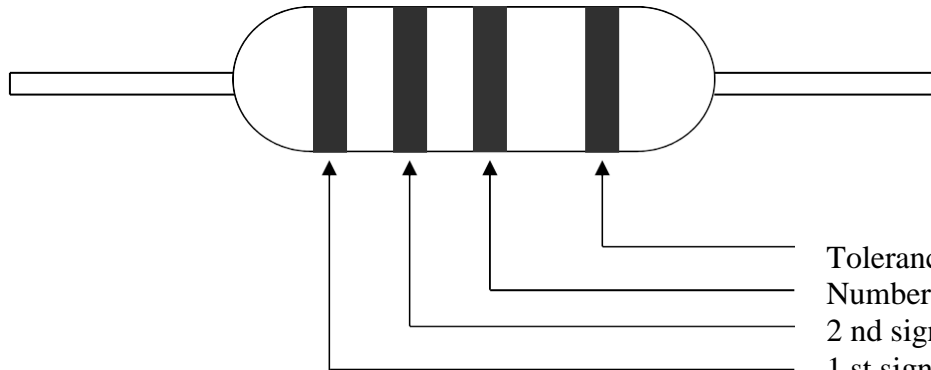

Color refer

Color	1 st Band	2 nd Band	3 rd Band	4 th Band
Black	0	0	10 <sup>0</sup>	
Brown	1	1	10 <sup>1</sup>	
Red	2	2	10 <sup>2</sup>	±2.0%
Orange	3	3	10 <sup>3</sup>	
Yellow	4	4	10 <sup>4</sup>	
Green	5	5	10 <sup>5</sup>	
Blue	6	6	10 <sup>6</sup>	
Violet	7	7	10 <sup>7</sup>	
Grey	8	8	10 <sup>8</sup>	
White	9	9	10 <sup>9</sup>	
Gold			10 <sup>-1</sup>	±5.0%
Silver			10 <sup>-2</sup>	±10.0%

### 6. Construction and Dimension

#### 6-1. Construction

- a. Lead Wire
- b. End Cap
- c. Carbon Film
- d. Ceramic Rod
- e. Epoxy Resin
- f. Color Code

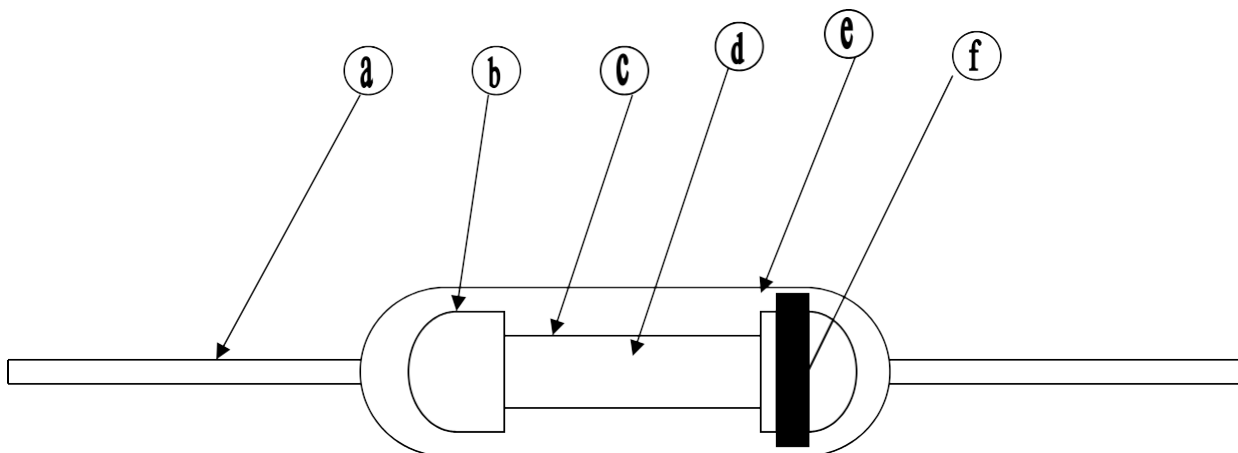

6-2 Dimensions

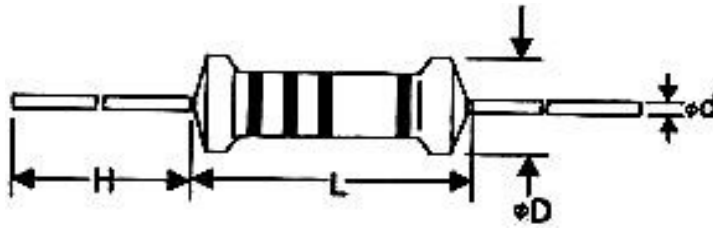
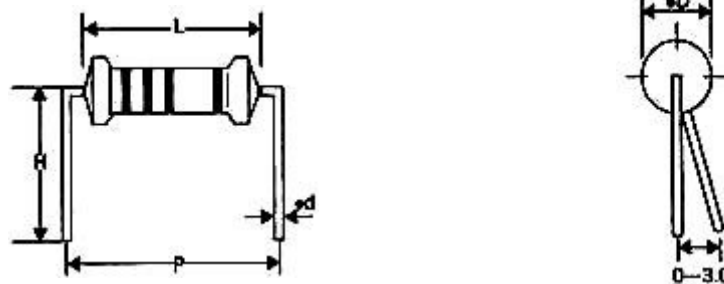

TABLE:

WATTS	L	D	H	d ± 0.05mm
1/6W 1/8W 1/16W	3.2±0.3	1.8±0.3	28±2.0	0.4
1/4WS				
1/4W	6.0±0.5	2.3±0.3	28±2.0	0.45
1/2WS				
1/2W	9.0±0.5	3.2±0.3	26.0±2.0	0.52
1WS				
1W	11.0±1.0	4.2±0.5	35.0±3.0	0.65
2WS				
2W	15.0±1.0	5.0±0.5	33.0±3.0	0.72
3WS				
3W	17.0±1.0	6.0±0.5	36.0±3.0	0.72
5WS				
5W	24.0±1.0	8.0±1.0	33.0±3.0	0.72

**7. FORMED DIMENSIONS**

7-1. M – TYPE



WATTS	DIMENSIONS (mm)				
	L	P±1.0	D	d±0.05	H±1.0
1/6W/1/8W/1/16W /1/4WS	3.2±0.3	6	1.8±0.3	0.40	8.0
1/4W/1/2WS	6.0±0.5	10	2.3±0.3	0.45	8.0
1/2W/1WS	9.0±0.5	12.5/15	3.2±0.3	0.52	8.0
1W/2WS	11.0±1.0	15	4.2±0.5	0.65	10
2W/3WS	15.0±1.0	20	5.0±0.5	0.72	10
3W/5WS	17.0±1.0	25	6.0±0.5	0.72	10
5W	24.0±1.0	33	8.0±1.0	0.72	10

7-2 . MB – TYPE

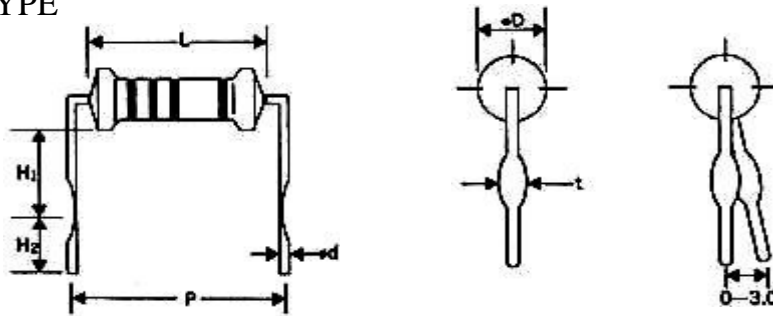

WATTS	DIMENSIONS (mm)						
	L	P±1.0	D	d±0.05	H1±1.0	H2±1.0	t±0.2
1/2W/1WS	9.0±0.5	12.5	3.2±0.3	0.52	10.5	5.0	1.20
1W/2WS	11.0±1.0	15	4.2±0.5	0.65	10.5	5.0	1.25
2W/3WS	15.0±1.0	20	5.0±0.5	0.72	10.5	5.0	1.25
3W/5WS	17.0±1.0	25	6.0±0.5	0.72	10.5	5.0	1.25
5W	24.0±1.0	30	8.0±1.0	0.72	10.5	5.0	1.25

7 – 3. F – TYPE

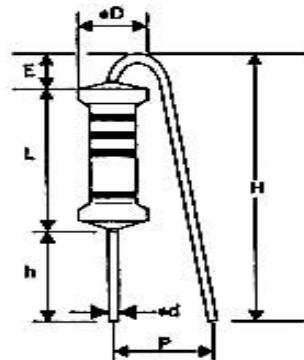

WATTS	DIMENSIONS (mm)						
	L	P±1.0	D	d±0.05	h±1.0	H±1.0	E <sub>max</sub>
1/4W/1/2WS	6.0±0.5	6-8	2.3±0.3	0.45	8.0	14	3
1/2W/1WS	9.0±0.5	6-8	3.2±0.3	0.52	8.0	18	3.5
1W/2WS	11.0±1.0	6-8	4.2±0.5	0.65	8.0	20	3.5
2W/3WS	15.0±1.0	6-8	5.0±0.5	0.72	8.0	25	3.5
3W/5WS	17.0±1.0	6-8	6.0±0.5	0.72	8.0	30	3.5

7 – 4. FK2-TYPE,FK1 – TYPE AND FKK-TYPE

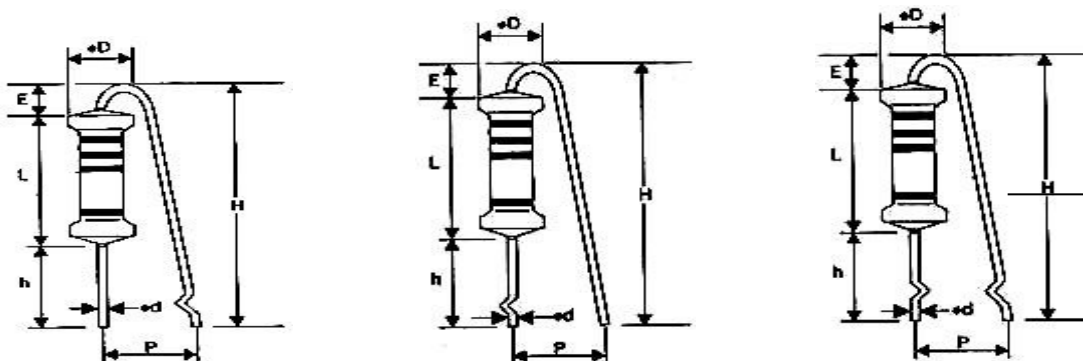

WATTS	DIMENSIONS(mm)						
	L	P±1.0	D	d±0.05	h+1/-0	H±1.0	E <sub>max</sub>
1/2W/1WS	9.0±0.5	5-7	3.2±0.5	0.52	8	18	3.5
1W/2WS	11.0±1.0	5-9	4.2±0.5	0.65	8	20	3.5
2W/3WS	15.0±1.0	5-9	5.0±0.5	0.72	8	25	3.5
3W5WS	17.0±1.0	5-10	6.0±0.5	0.72	8	30	3.5

## 8. Taping Dimensions

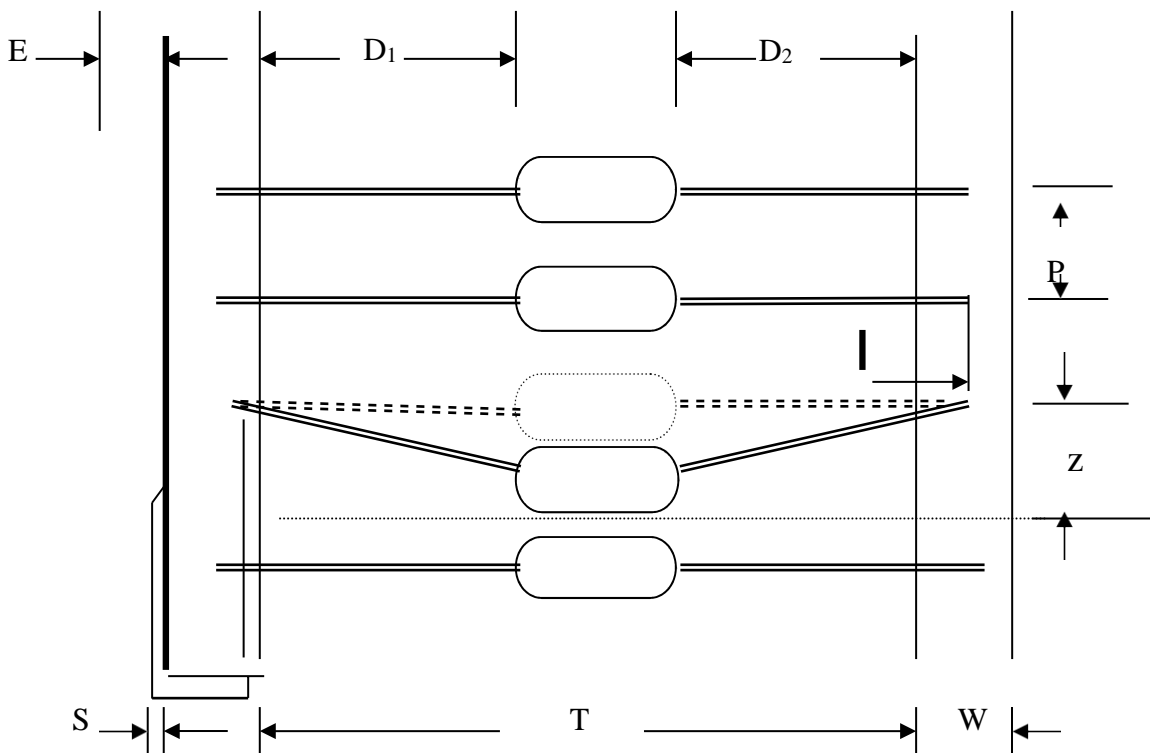

WATTS	Type	T	p±0.5	W±0.5	D <sub>1</sub> -D <sub>2</sub> MAX	E MAX	Z MAX	S MAX	I MAX
1/6W/1/8W 1/16W/1/4WS	T26(T34)	26±1.5	5	6	0.8	0	1.2	0.8	3.2
	T52(T60)	52±1.5	5	6	0.8	0	1.2	0.8	3.2
1/4W 1/2WS	T26(T34)	26±1.5	5	6	0.8	0	1.2	0.8	3.2
	T52(T60)	52±1.5	5	6	0.8	0	1.2	0.8	3.2
1/2W/1WS	T52(T60)	52±1.5	5	6	0.8	0	1.2	0.8	3.2
1W/2WS	T73(T81)	73±1.5	5	6	0.8	0	1.4	0.8	3.2
2W/3WS	T73(T81)	73±1.5	10	6	0.8	0	1.4	0.8	3.2
3W/5WS	T73(T81)	73±1.5	10	6	0.8	0	1.4	0.8	3.2
5W	T84(T91)	73±1.5	10	6	0.8	0	1.4	0.8	3.2

**9 . PACKING**

9 - 1. TAPING TYPE

LABEL SPECIFICATION

1. TYPE
2. WATTS TOLERANCE
3. RESISTANT QUANTITY C.C.OHM ENTERPRISE CO, LTD
4. P/N
5. LOT NO.

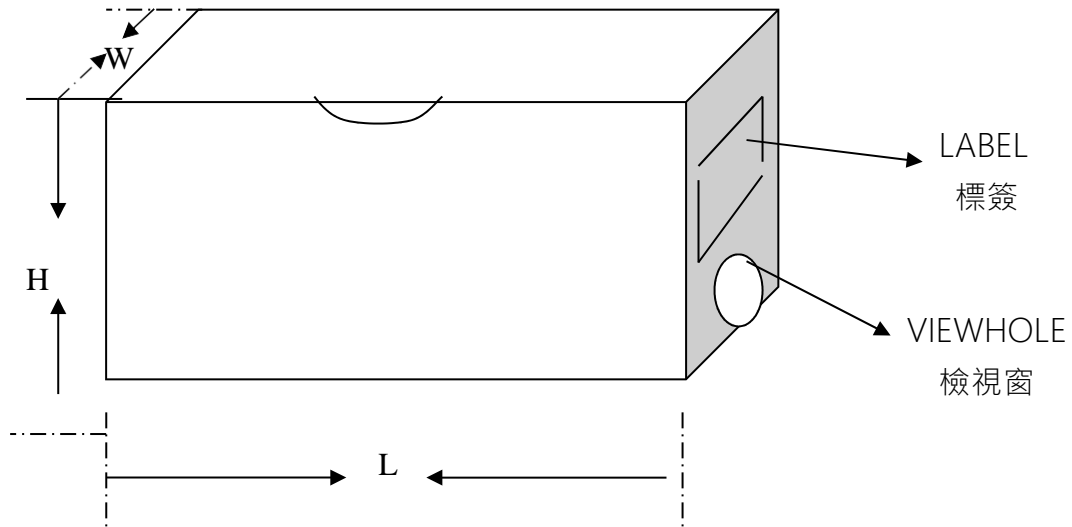

TYPE	WATTS	W(mm)	H(mm)	L(mm)	Q·TY(pcs)
T26(T34)	1/6W 1/8W 1/16W 1/4WS	50	67	260	5000
	1/4W/ 1/2WS	50	100	260	5000
T52(T60)	1/6W / 1/8W	80	72	266	5000
T52(T60)	1/16W 1/4WS				
T52(T60)	1/4W/ 1/2WS	80	100	260	5000
T52(T60)	1/2W/ 1WS	80	85	260	2000
T73(T81)	1W/ 2WS	110	80	270	1000
T73(T81)	2WS/ 3WS	110	92	270	1000
T73(T81)	3W/5WS	110	92	270	500
T84(T91)	5W	110	92	270	250

9 - 2. BULK

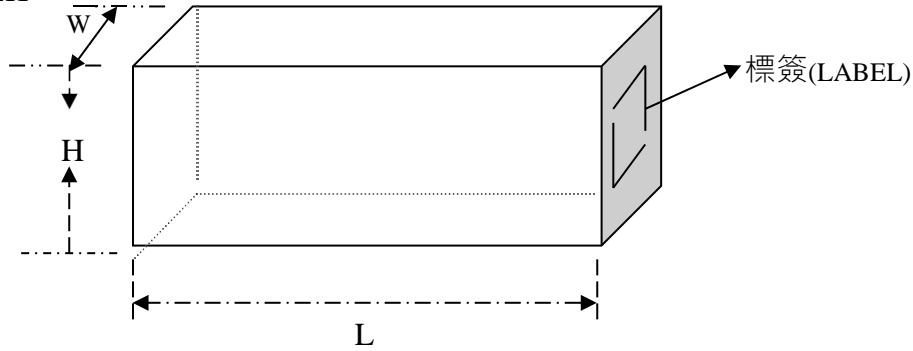

WATTS		TYPE	L(mm)	W(mm)	H(mm)	POLY BOG	BOX(pcs)
1/6W 1/8W	1/16W 1/4WS	P	240	140	76	1000	20000
1/4W	1/2WS	P	240	140	76	500	10000
1/2W	1WS	P	240	140	76	500	5000
1W	2WS	P	240	140	76	200	2000
2W	3WS	P	240	140	76	100	1500
3W/5WS		P	240	140	76	100	1000
5W		P	240	140	76	50	500